

IMU (Inertial Measurement Unit) RS422 INTERFACE

■ GENERAL DESCRIPTION

The M-G552PR1 is a small form factor inertial measurement unit (IMU) with 6 degrees of freedom: tri-axial angular rates and linear accelerations, and provides high-stability and high-precision measurement capabilities with the use of high-precision compensation technology.

The M-G552PR1 features a built-in attitude angle output function using an extended Kalman filter optimized for high-speed operation and highly accurate attitude angle (Roll/Pitch). This exceptional real time performance is achieved using our unique DSP processing architecture for efficiency, and low power consumption. The application or system level power consumption and complexity can be reduced by offloading the high-speed processing from the host system that would otherwise be necessary to achieve highly dynamic posture angle.

A variety of calibration parameters are stored in memory of the IMU, and are automatically reflected in the measurement data being sent to the application after the power of the IMU is turned on.

With RS422 interface support for host communication, the M-G552PR1 reduces technical barriers for users to introduce inertial measurement and minimizes design resources to implement inertial movement analysis and control applications. This unit is packaged in a water-proof and dust-proof metallic case. It is suitable for use in industrial and heavy duty applications.

The features of the IMU such as high stability, high precision, and small size make it easy to create and differentiate applications in various fields of industrial systems.

■ FEATURES

Item	Specification
Sensor	
Integrated sensor	SEIKO EPSON inertial measurement sensor Low-noise, High-stability Gyro bias instability : 1.2 deg/hr Angular random walk : 0.08 deg/ $\sqrt{\text{hr}}$ Initial bias error : 0.1 deg/s (1σ) / 4mG(1σ) 6 Degree of freedom Triple Gyroscope : ± 450 deg/s Tri-axis Accelerometer : ± 10 G Tilt function Inclination mode : ± 80 deg Euler mode: ± 180 deg(Pitch), ± 45 deg(Roll) Resolution: 0.01deg , Static : ± 0.2 deg (1σ), Dynamic : ± 0.2 deg (1σ) 16bit / 32bit data resolution Calibrated stability (Bias, Scale factor, Axial alignment)
Interface	
Protocol (DL layer)	RS-422 (TX/RX Pair, Full-duplex transmission)
Bit rate	460.8k bps (default) / 230.4k bps / 921.6k bps
Cable length	250m (max)
Terminator	Included (120 Ω typ)
Environment	
Voltage supply	9 to 32 V
Power consumption	42 mA
Operating temperature range	-30 to +80 °C
External dimension	
Outer packaging	Overall metallic shield case
Size	65 x 60 x 30mm (Not including projection.)
Weight	115 g
Interface connector	M12, 8pin-male, waterproof
Waterproof, Dustproof:	IP67 equivalent

Item	Specification
Random vibration	1 hour at 20Grms MIL-STD-810, METHOD 514.x ANNEX E, Category24
Sine sweep vibration	4 hours / axis at 10G MIL-STD-202G, METHOD 204
Mechanical shock	1,000G, Half-sine 0.5ms, once per \pm each axis(6times)
Regulation	
EU	CE marking (EN61326/RoHS Directive) Class A
USA	FCC part15B Class A

■ APPLICATIONS

- Motion and vibration measurement
- Platform stabilization
- Attitude detection for unmanned systems
- Vibration control and stabilization

OUTLINE DIMENSION

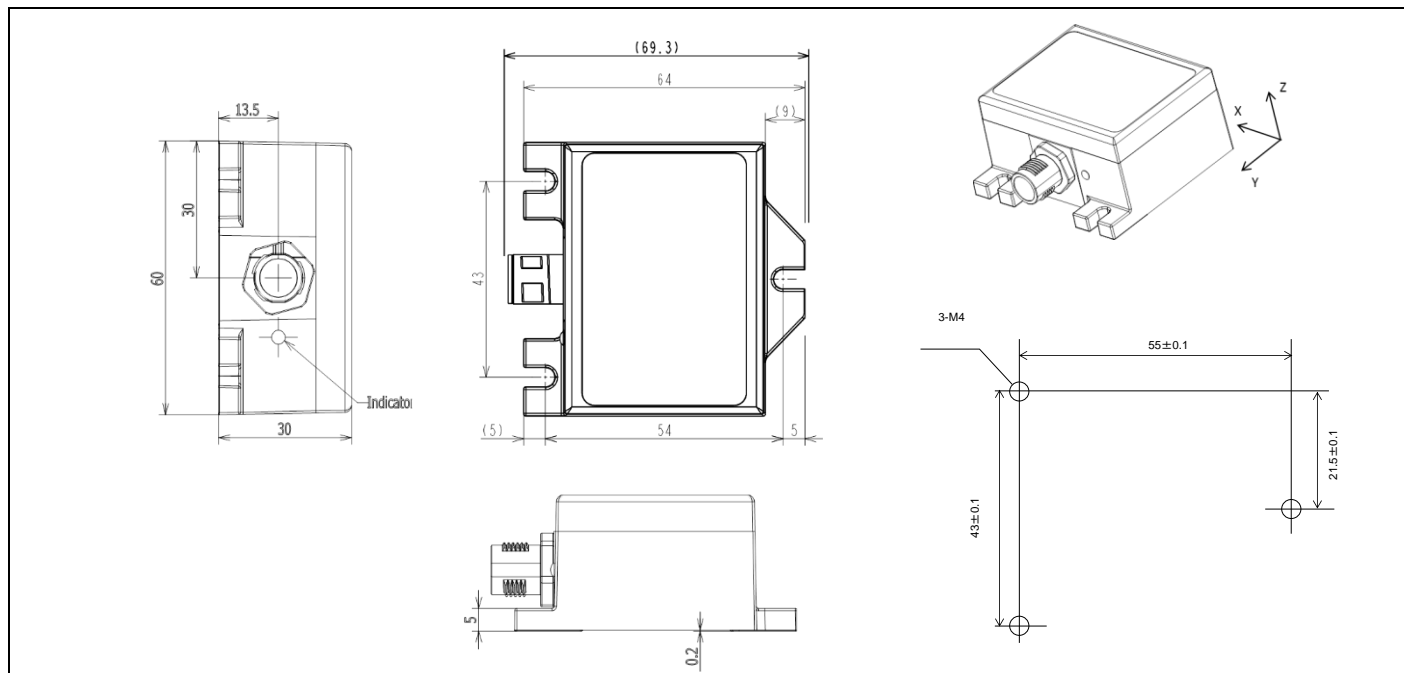

Outline Dimensions (millimeters)

NOTICE:

No part of this material may be reproduced or duplicated in any form or by any means without the written permission of Seiko Epson. Seiko Epson reserves the right to make changes to this material without notice. Seiko Epson does not assume any liability of any kind arising out of any inaccuracies contained in this material or due to its application or use in any product or circuit and, further, there is no representation that this material is applicable to products requiring high level reliability, such as, medical products. Moreover, no license to any intellectual property rights is granted by implication or otherwise, and there is no representation or warranty that anything made in accordance with this material will be free from any patent or copyright infringement of a third party. This material or portions thereof may contain technology or the subject relating to strategic products under the control of the Foreign Exchange and Foreign Trade Law of Japan and may require an export license from the Ministry of Economy, Trade and Industry or other approval from another government agency.

All brands or product names mentioned herein are trademarks and/or registered trademarks of their respective companies.

©Seiko Epson Corporation 2021, All rights reserved

SEIKO EPSON CORPORATION

DEVICE SALES & MARKETING DEPT.

29th Floor, JR Shinjuku Miraina Tower, 4-1-6 Shinjuku, Shinjuku-ku,
Tokyo, 160-8801, Japan
Phone: +81-3-6682-4322 FAX: +81-3-6682-5016

First issue May, 2020 in Japan
Revised Apr, 2021
Rev.1.0